

Effects of indefinite pronouns and traces on verb stress in German

Hubert Truckenbrodt

To appear in: *Prosody Matters: Essays in Honor of Lisa Selkirk*, Hg. Toni J. Borowsky, Shigeto Kawahara und Takahito Shinya. London: Equinox Publishing.

Introduction

Kratzer and Selkirk (2007) develop an innovative account of phrasal stress in terms of phases (see Chomsky 2008). In developing the account with German examples, they notice an interesting difference concerning the indirect effect of indefinite pronouns as opposed to traces on whether stress is assigned to a following verb. This effect is further explored in this paper, along with some related issues.

By way of background, notice first that in all-new-sentences, a nonpronominal subject and a non-pronominal object both receive phrasal stress as in (1). (I indicate stress by underlining. The last stress is strengthened to the strongest of the clause, which I indicate by double underlining.) The absence of stress on the final verb is in some sense tied to the presence of the preceding stressed direct object (see Gussenhoven 1983, Krifka 1984, Selkirk 1984 and much later literature). If the verb is preceded by an adjunct as in (2) the final verb is stressed.

(1) [What happened while I was gone?]

Ein Mann hat ein Buch gekauft.

a man has a book bought

'A man has bought a book.'

(2) [What are you laughing about?]

Ein Mann hat während einer Vorstellung geschlafen.

a man has during a show slept

'A man has slept during a show.'

There is a sense, then, in which a direct object exempts the following verb from being stressed. Can the subject of a transitive verb likewise exempt the final verb from being stressed, across a pronoun or across the trace of a direct object? Kratzer and Selkirk (2007) show that this is not possible across an intervening indefinite object pronoun as in (3). Interestingly, they also show that, when the direct object is given and scrambled as in (4), the subject does exempt the final verb from requiring stress. Their examples show the stress-patterns of all-new sentences, except where otherwise noticed (as with the given constituent in (4)).

(3) Ich hab gehört, dass Maria was gekauft hat.

H have heard that Maria something bought has

'I have heard that Maria has bought something.'

(4) Ich weiss, dass dieses Haus_G Mafiosi besitzen.

I know that this house Mafiosi own

'I know that Mafiosi own this house.'

In this paper, further cases of this contrast are introduced, the contrast is extended to configurations with an indirect and a direct object, and a related case from Kratzer and Selkirk

(2007) involving PPs without phrasal stress is addressed. The data is introduced in section 1. In Section 2 I review the account of Kratzer and Selkirk (2007) and offer an extension for the cases involving indirect and direct object. In Section 3 I discuss an account in the theory in terms of Stress-XP (Truckenbrodt 2007), though the case of the stressless PPs will remain open. I will not seek a choice between the two accounts, and will conclude by addressing the relation of the two accounts in Section 4.

1. Stress patterns with indefinite and definite pronouns

1.1. Indirect object + direct object + verb

The perspective discussed here is that the syntax plays a role in the assignment of phrasal prosodic structure and phrasal stress that can be stated independently of the deaccenting role of givenness (Ladd 1983, Féry and Samek-Lodovici 2006, Selkirk 2006) and independently of the role of focus (Jackendoff 1972, refined in Truckenbrodt 1995:Ch.4, Rooth 1996). Context questions are employed to ensure that a sentence, or the relevant part of it, consists of new elements inside of a larger focus.

Again some background first: A stressed new indefinite (i.e. unscrambled) direct object makes a following verb stressless obligatorily, as in (5).

- (5) [What did she do?]
 a. # Sie hat ein Buch gekauft.
 b. Sie hat ein Buch gekauft.
 she has a book bought
 'She has bought a book.'

Now, an indirect object and a direct object both carry phrasal stress. Here the stressed direct object has the effect that the verb need not carry phrasal stress:

- (6) [What did she do?]
 Sie hat einem Kind ein Buch vorgelesen.
 she has a.DAT child a book read
 'She has read a book to a child.'

In (7) the direct object is replaced with an indefinite pronoun. Can the indirect object exempt the final verb from carrying phrasal stress in this case? As shown, stress on the verb as in (7a) is obligatory in such a configuration. (7b) is not a possible stress pattern in this case, unless the verb 'vorgelesen' is contextually given.

- (7) [What did she do?]
 a. Sie hat einem Kind (et)was vorgelesen.
 b. # Sie hat einem Kind (et)was vorgelesen.
 she has a.DAT child something read
 'She has read something to a child.'

In (8) the direct object is realized by a definite object pronoun. This is fronted within the middle field of the clause obligatorily. As shown in (8), the stress facts change in the case considered here. Both stress patterns are now possible. Importantly, the stressless verb in (8b) is allowed, while it is disallowed in (7b).

- (8) [What did she do next with the book?]
 a. Sie hat *es* einem Kind vorgelesen.
 b. Sie hat *es* einem Kind vorgelesen.
 she has it a.DAT child read
 'She has read it to a child.'

The same two stress-patterns are found when the direct object is not expressed, as in (9).

- (9) [What did she do?]
 a. Sie hat einem Kind vorgelesen.
 b. Sie hat einem Kind vorgelesen.
 she has a.DAT child read
 'She has read to a child.'

In sum, stress on the verb is possible in the absence of a stressed direct object; in addition, a stressless verb is possible so long as the position of the direct object is phonetically empty; an intervening indefinite pronoun blocks the possibility of the stressless verb.

1.2. Subject + direct object + verb

As reviewed initially in this paper, a subject and a following unscrambled direct object both receive phrasal stress, and a following verb remains unstressed. Another example is shown in (10). I employ an initial adverbial for reasons explained later in this paper.

- (10) [What happened on Tuesday?]
 Am Dienstag hat ein Kunde ein Buch geklaut.
 on Tuesday has a customer a book stolen
 'On Tuesday a customer has stolen a book.'

The observation of Kratzer and Selkirk (2007) concerning a direct object pronoun is reproduced in (11). The verb cannot be stressless as in (11b) when the subject is followed by an indefinite direct object pronoun. (It could be stressless only if it were contextually given.)

- (11) [What happened on Tuesday?]
 a. Am Dienstag hat ein Kunde *etwas* geklaut.
 b. # Am Dienstag hat ein Kunde *etwas* geklaut.
 on Tuesday has a customer something stolen
 'On Tuesday a customer has stolen something.'

When the direct object is a personal pronoun that is moved to the left of the subject, as in (12), the stressless verb is possible, as in (12b). This is parallel to the example (4) of Kratzer and Selkirk (2007). Alternatively, stress on the verb is possible, as in (12a).

- (12) [What happened to the new hammer?]
 a. Am Dienstag hat *ihn* ein Kunde geklaut.
 b. Am Dienstag hat *ihn* ein Kunde geklaut.
 on Tuesday has it a customer stolen
 'On Tuesday a customer has stolen it.'

Kratzer and Selkirk (2007:122) observe for their example (4) that it does not allow the alternative stress-pattern with the verb stressed. I believe this may be because of the following reason. It seems to me that in the domain of optionality where the syntax does not determine the stress, subtle preferences arise due to expectability of the predicates involved. These may be more intricate than the givenness that we normally take into account. Thus, in (4) it may be that 'Mafiosi' and 'house' together make the verb 'own' in some sense expected. I seek to avoid this by using 'customer' and 'steal' in (12). Further examples to document the optionality are shown in (13) - (16).

- (13) [What do you know about Peter's trip?]
 a. Überall haben *ihn* Frauen verehrt.
 b. Überall haben *ihn* Frauen verehrt.
 everywhere have him women admired
 'Women admired him everywhere.'
- (14) [What did Peter see on his trip?]
 a. Überall haben Frauen *jemand* verehrt.
 b. # Überall haben Frauen *jemand* verehrt.
 everywhere have women someone admired
 'Women have admired someone everywhere.'
- (15) [What happened to the apparatus?]
 a. In der Werkstadt haben *ihn* Fachleute geölt.
 b. In der Werkstadt haben *ihn* Fachleute geölt.
 in the garage have it specialists oiled
 'Specialists have oiled it in the garage.'
- (16) [What happened in the afternoon?]
 a. In der Werkstadt haben Fachleute *etwas* geölt.
 b. # In der Werkstadt haben Fachleute *etwas* geölt.
 in the garage have specialists something oiled
 'Specialists have oiled something in the garage.'

As seen initially, then, a subject can exempt a following transitive verb from being stressed across the trace of the direct object, but not across an intervening indefinite pronoun. The patterns are parallel to those of indirect and direct object.

1.3. Directional and locative PPs

Kratzer and Selkirk (2007:107f) discuss a pattern of stress from Uhmann (1991) and others that is unexpected for earlier accounts that assign phrasal stress to each verbal argument, including the account in terms of Stress-XP. When a direct object (or unaccusative subject) is followed by a directional or locative PP, the PP need not carry phrasal stress. (Agentive verbs seem to be excluded from this, as Kratzer and Selkirk 2007 show.) In (17), the PP 'an einen Freund' does not carry phrasal stress. Importantly, this pattern of stress is possible even if the PP is not contextually given.

- (17) ... dass ein Junge eine Geige an einen Freund schickte
 that a boy a violin to a friend sent
 '... that a boy sent a violin to a friend.'

2.2. A topic phase

Kratzer and Selkirk (2007) adopt the suggestion of Jäger (2001) that sentences have to have a syntactically represented topic. In assessing stress-patterns in clauses that only consist of subject and verb, this is important: If the sentence takes the subject as its topic, subject and verb will both be stressed, though not because of independent demands of the syntax, but because of demands of the topic-requirement of the sentence. Following Jäger, one can avoid this with the help of an initial overt sentence topic. This disengages the subject from the topic-requirement and allows us to study the remaining effects of the syntactic structure on phrasal stress. Jäger also argues that the effect of stage- vs. individual-level predicates on argument position and interpretation (Diesing 1992, Kratzer 1995) is real but indirect, mediated by this topic requirement.

Kratzer and Selkirk (2007:113) show that when this is taken into account, it becomes apparent that unergative verbs in German show an all-new stress pattern in which the subject is stressed and the verb stressless. Two additional examples are shown in (21).

- (21) a. Im Wohnzimmer hat ein Besucher telefoniert.
 in_the livingroom has a visitor telephoned
 'A visitor has telephoned in the livingroom.'
 b. In der Küche haben einige Männer gearbeitet.
 in the kitchen have some men worked
 'Some men have worked in the kitchen.'

In the absence of reasons to contrast the verb or to take the subject as in some way given, a stress-pattern in which the verb is also stressed is dispreferred in such sentences.

Kratzer and Selkirk (2007) postulate a topic phrase TopP between CP and TP. They suggest that the TopP is itself a phase. In this way both the topic and the following subject in examples like (21) receive phrasal stress. This is shown in (22), the embedded clause equivalent of (21a). The topic 'im Wohnzimmer' in Spec,TopP receives phrasal stress as the highest XP of the TopP spellout domain of the CP phase. The subject 'ein Besucher' in Spec,TP receives phrasal stress as the highest XP of the TP spellout domain of the TopP phase.

- (22) dass im Wohnzimmer ein Besucher telefoniert hat
 [CP-PHASE-1 [TopP-SPELLOUT-1]]
 that [TopP-PHASE-2 [TP-SPELLOUT-2]]
 in_the livingroom a visitor telephoned has

2.3. Verb stress and verb position

On the VP phase, the VP cannot itself be designated as the XP in which stress needs to be located, since this would not direct the stress to any constituent inside of the VP, such as the direct object in (19). So the stress-receiving element is defined in (18) as the highest XP *inside of* the spellout domain. In a spellout domain VP, this is the highest XP inside of VP. In (19), for example, this is the direct object.

By consequence, (18) will never direct stress to the verb. A natural amendment to (18) is then the condition in (23) from Kratzer and Selkirk (2007:110). It requires a prosodic major phrase, and thus ultimately phrasal stress, inside of a spellout domain. Thus, if there is no highest XP to be stressed by (18) inside of the spellout domain, stress is assigned to some element in the spellout domain, which is then the verb.

- (31) [What did he trade against these screws?]
 Er hat einem Kunden gegen diese Schrauben_G Nägel eingetauscht.
 he has a.DAT customer against these screws nails traded

Summing up, the extension of the stress patterns involving indefinite pronouns and traces to ditransitive verbs can be accommodated in the theory of Kratzer and Selkirk 2007 with plausible additional means: an additional layer in a VP shell representation, and a second topic phrase above the direct object.

3. Account in terms of Stress-XP

3.1. Background on Stress-XP

Like so much in this area, Stress-XP builds on work by Lisa Selkirk. Stress-XP builds on the claim of the universal relevance of XPs to the syntax-phonology interface, elaborated in terms of Align-XP for Chi Mwi:ni in Selkirk (1986), for Shanghai Chinese in Selkirk and Shen 1990 (here the restriction on lexical XPs plays an important role) and for Japanese in Selkirk and Tateishi (1991). See also Selkirk (1995) for implementation of edge-alignment with XPs in Optimality Theory and for some consequences of it in English.

Stress-XP is from Truckenbrodt (1995). It was applied to German briefly in Samek-Lodovici (2005) and Truckenbrodt (2006, (2007) and in some more detail in Truckenbrodt and Darcy (2010). See Féry and Samek-Lodovici (2006) for application to English, Samek-Lodovici 2005 for application to Italian and a range of other languages.

The constraint is formulated as follows:

- (32) Stress-XP: Each lexical XP must contain a beat of phrasal stress.

The effects of Stress-XP are to be assessed on the assumption that phrasal stress is assigned only where forced by this constraint. The assumption that the last phrasal stress thus assigned is strengthened to the strongest of the intonation phrase is shared with the account of Kratzer and Selkirk (2007).

In the Stress-XP account, each argument and each adjunct correctly receives phrasal stress because, and so long as, it includes a lexical XP. The lexical XP requires phrasal stress by Stress-XP. I take DP, PP, vP, TP, and CP to be functional projections that do not invoke Stress-XP. Stress-XP is invoked by the lexical projections NP and VP (as well as AP), not discussed here). DP argument often contains a lexical NP, and it is this NP that requires phrasal stress by Stress-XP. These NPs in the arguments are bracketed in (33). If each of them attracts phrasal stress, the correct beats of phrasal stress are derived here. An adjunct such as [während einer [_{NP} Vorstellung]] in (2) likewise contains such a lexical XP, typically an NP as in this case, which correctly attracts stress by Stress-XP.

- (33) [_{NP} Peter] hat einem [_{NP} Kind] ein [_{NP} Buch] vorgelesen.
 Peter has a.DAT child a book read
 'Peter has read a book to a child.'

The theory in terms of Stress-XP claims in its favor a conceptual edge over earlier theories like that of Gussenhoven (1983, 1992): The argument-adjunct distinction in stress-assignment is not written into the account. Instead, it is derived from standard assumptions about the different syntactic structure of arguments and of adjuncts with the help of the simple formulation in (32). This relates to the application of Stress-XP to the lexical projection VP. An argument, as in (34a), is genuinely inside of the projection of the verb, the VP. The NP in

the argument needs to carry phrasal stress to satisfy Stress-XP. Given this phrasal stress on the argument, Stress-XP is also satisfied for the VP, since the stress on the argument is also stress inside of the VP. No additional stress is required on the verb following the argument. Matters are different for the adjunct, as shown in (34b). The adjunct to VP is not genuinely inside of VP. Instead, there is one segment of the VP, the lower one, which is a sister to the adjunct. For some purposes, including the assignment of thematic roles, this lower segment is decisive, i.e. the adjunct counts as being outside of VP. Truckenbrodt (1999) argued that the lower segment is also decisive for the syntax-prosody mapping. This is assumed here as well. With this, Stress-XP, applied to the VP in (34b), requires phrasal stress in this VP. Stress in this circled VP can only fall on the verb. Put differently, phrasal stress on the argument satisfies Stress-XP in (34a), where the following verb is only a head; in (34b), the verb following the adjunct is really a VP, and therefore requires phrasal stress by Stress-XP.

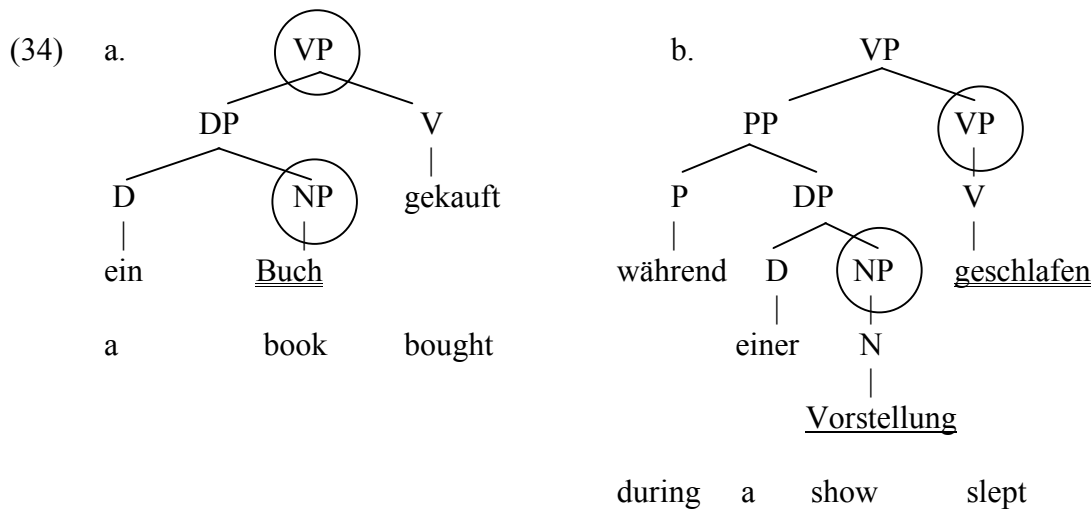

More generally, if a lexical XP is inside of another one (cf. the two circled lexical XPs in (34a)), no additional phrasal stress is required for the higher XP: A single instance of phrasal stress will satisfy Stress-XP for both projections. On the other hand, where two lexical XPs are disjointed and next to each other (cf. the two circles in (34b)), Stress-XP will of course require phrasal stress in each of them.

3.2. Pronouns and traces

The stress-pattern [... IO pron_{DO} V] in (7) suggests the presence of an internal VP as follows: [... IO [_{VP} pron_{DO} V]]. This VP will correctly attract stress by Stress-XP, which cannot fall on the pronoun for independent reasons (nor on the IO, which is crucially outside of this VP) and thus falls on the verb. (35a) is a structure of this kind that is suggested for verbal arguments by Haider and Rosengren (2003): The lowest argument joins with the verb to form a VP, higher arguments occur in VP-adjoined positions. In this structure, the circled VP that comprises the direct object and the verb invokes Stress-XP and thus correctly derives stress on the verb. In this paper I mainly employ VP shell structures as in the discussion of Kratzer and Selkirk 2007 above. The VP shell structure in (35b), crucially with a separate VP for direct object and verb, derives the correct stress pattern. The lower VP₂ of the shell-structure (circled) here invokes Stress-XP and derives the stress on the verb.

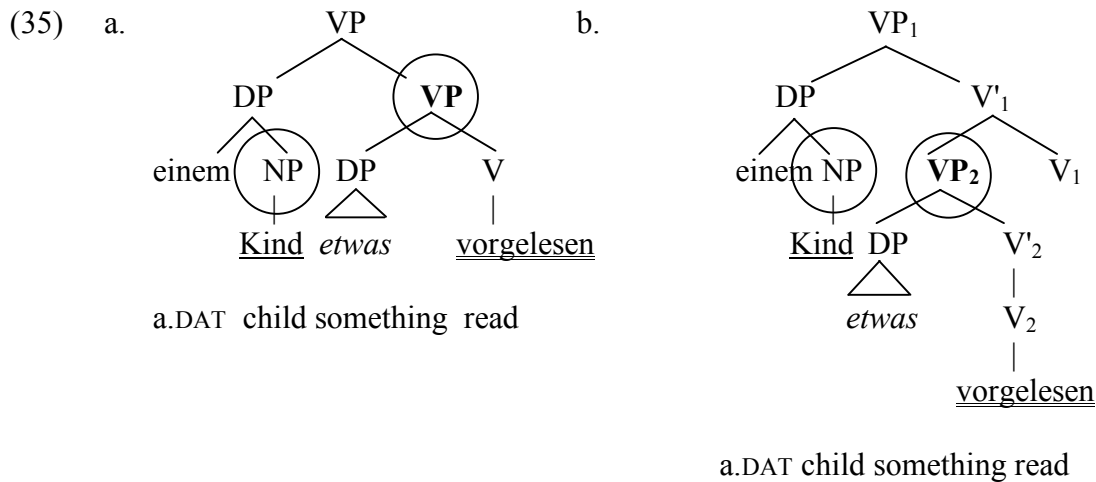

The VP-shell structure employed here also correctly derives the stressless verb in (33) as shown in (36). The lexical XPs are bracketed here. Stress in the direct object noun 'Buch' is also stress in VP₂ so that Stress-XP provides no reason to stress the final verb.

- (36) [Peter] hat [_{VP1} einem [Kind] [_{VP2} ein [Buch] vorgelesen]]
 Peter has a.DAT child a book read

Let us turn to the case involving the direct object trace in (8), where both stress-patterns [... IO t V] and [... IO t V] are allowed. The choice of the account turns on correctness of the Uniformity of Theta-assignment Hypothesis by Baker (1988:46):

- (37) *Uniformity of Theta-assignment Hypothesis* (UTAH)
 Identical thematic relationships between items are represented by identical structural relationships between those items at the level of D-structure.

If the UTAH is correct, it entails a fixed underlying order of the arguments for a given German verb. For example, the verb 'vorlesen' has an agent, a beneficiary/experiencer and a theme argument. The UTAH requires that the underlying order of these is constant regardless of their surface order. German word-order in the Mittelfeld is fairly flexible. A standard analysis for this flexibility is to assume an underlying order (either the unmarked word order or an order inferred by other syntactic arguments) and to hold scrambling responsible for the flexibility. See, for example, Frey (1993) and Haider and Rosengren (2003). However, it has also been suggested by Bayer and Kornfilt (1994), Fanselow (2001, (2003), and others, that the assumption of a fixed underlying order be given up and that word order in the Mittelfeld is base-generated. This amounts to giving up the UTAH.

An account that allows different underlying orders to be base-generated can derive the two stress-patterns as shown in (38). 'Kind' is stressed as an NP in both a. and b. Where it is followed by the trace of the direct object in a lower VP, this lower VP attracts stress as in (38a), in parallel to (35a). The assumption of flexible underlying order also allows (38b), where the indirect object is base-generated in the lowest VP, thus exempting the following verb from being stressed.

- (38) *Structures in an account that allows different underlying orders*
- a. es_i [_{VP} einem Kind [_{VP} t_i vorgelesen]].
 b. es_i [_{VP} t_i [_{VP} einem Kind vorgelesen]].
 it a.DAT child read

In that account, the difference between the indefinite pronoun in situ in (7) and the dislocated definite pronoun in (22) is due to the fact that the dislocated pronoun need not originate in the lowest VP, while a pronoun in situ must be in the lowest VP due to its overt position.

Here I pursue an account that retains the spirit of the UTAH, as does Ramchand (2008). Following Kratzer and Selkirk (2007), I relate the difference between pronoun and trace to the position of the verb in its shell. As in Kratzer and Selkirk's account, a higher position of the verb is to be prohibited in the presence of the indefinite direct object pronoun, as shown in (39). Here the verb is to receive the phrasal stress assigned due to Stress-XP in VP₂. If it were to stand in a higher position, there would be no incentive for stressing it. We are led assume that raising is not an option in this case.

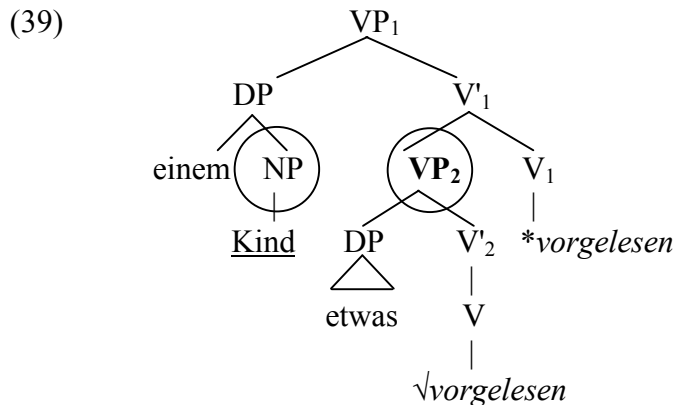

a.DAT child something read

I assume for concreteness that the verb always raises in its shell for theta-role assignment, and that its traces are copies of the verb. The question at issue is then which of these copies is spelled out.

In the case of the direct object trace in (8), one would ideally want to allow the structure (40a) with a low verb position as well as the structure (40b) with a higher verb position. In (40a), Stress-XP, applied to VP₂, will lead to stress on the verb. In (40b), VP₂ is empty-headed and phonetically empty. By the Lexical Category Condition (LCC), a general provision formulated in Truckenbrodt (1999), lexical XPs invoke the phrasal mapping constraints but neither functionally headed XPs nor empty-headed XPs do. (The distinction between lexical and functional elements goes back to Selkirk and Shen 1990 and Selkirk 1995.) VP₂ in (40b) is empty-headed (and phonetically empty), and so does not invoke Stress-XP by this general provision. VP₁ is now overtly headed and so invokes Stress-XP. This is satisfied without stress on the verb, since VP₁ contains stress on the word 'Kind', which is independently required by the application of Stress-XP to this NP. This derives the stress-pattern with the stressless verb.

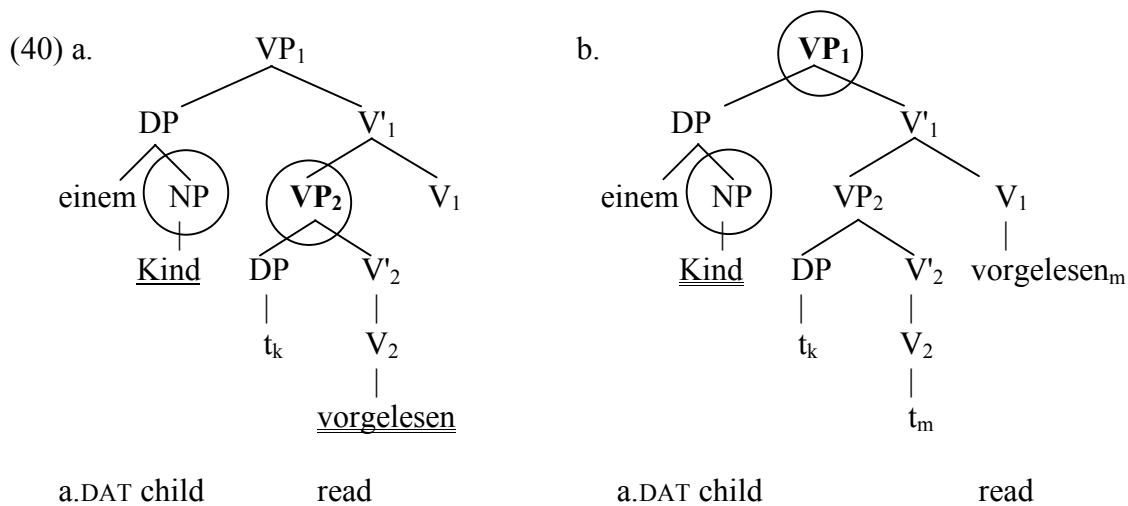

Why would low spellout be the only option in (39) and high spellout be allowed in (40)? The present account cannot invoke the economy considerations suggested by Kratzer and Selkirk (2007) for their account. A different possibility outlined here is a combination of the traditional headedness parameter in (41) with a weakened version of the Linear Correspondence Axiom (LCA) of Kayne (1994). The weakened LCA, here wLCA, orders only overt elements. Furthermore, adjuncts are ignored here. For the purposes at hand, the much-simplified version in (42) is sufficient.

(41) The VP is head-final in German.

(42) wLCA

For overt specifiers, overt heads and overt complements:

A specifier of XP precedes X and any complement of X.

A head precedes its complement.

(39) is in accord with the wLCA so long as the verb does not raise in its shell: The indirect object, a specifier of VP_1 , precedes the complement VP_2 of V_1 . The direct object, in specifier position of VP_2 , precedes the head V_2 .

The wLCA prohibits a higher spellout of the verb in this structure. If the verb were to be spelled out in the position of V_1 , it would be an overt head that follows its complement VP_2 , in violation of the wLCA. (It would have to follow the pronoun because of the headedness parameter (41).) Notice that only overt elements matter to the wLCA in (42). A phonetically empty verb V_1 is therefore not relevant to the wLCA.

Where the direct object position is occupied by a phonetically empty trace as in (40), spellout of the verb in the higher position in (40b) is not blocked by the wLCA. This is because only phonetically overt elements are ordered by the wLCA in (42). (40b) does not violate the wLCA, since VP_2 , the complement of V_1 is empty in this structure and thus not ordered by the wLCA. Among the overt elements, the indirect object in the specifier position of VP_1 precedes the head V_1 , as required. We may tentatively assume, then, that the spellout positions in (40a) and (40b) are both allowed, and that the optionality in stress-assignment in (8) is optionality between these two structures.

Let us then briefly turn to the syntactic cases involving a subject, a direct object and the verb. It was seen above that the stress-facts of this case (section 1.2.) are parallel to the cases involving an indirect object, a direct object and a verb (section 1.3.). The account employs the structure used throughout in which the direct object stands in the specifier of a separate VP as in (43). The account is parallel to the account of the objects in a ditransitive

structure above (here with the subject in place of the indirect object above). Raising of the verb needs to be constrained by the wLCA, in parallel to (39) and (40).

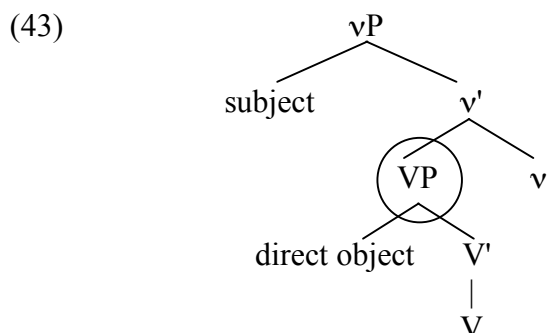

The projection hosting the subject is the functional vP. Notice that in the examples discussed here, the verb receives stress only in the application of Stress-XP to the lower (and always lexical) VP.

3.3. Stressless PPs

The stress-pattern with stressless locative and directional PPs presents what seems to be a serious problem for the account in terms of Stress-XP. As shown in (44), there is a lexical NP in the PP, and Stress-XP would predict phrasal stress on this NP. The surprise here is with the fact that the stressless PP is allowed even if the PP is new. (I concur with the assessment of Kratzer and Selkirk 2007 that stress on the PP is also a possibility.)

- (44) ... dass ein [Junge] eine [Geige] an einen [Freund] schickte
 that a boy a violin to a friend sent
 '... that a boy sent a violin to a friend.'

I agree with Kahnemuyipour (2004) and Kratzer and Selkirk (2007) that such stress-patterns motivate exploring new paths in this domain. Still, for me personally it is too early to give up Stress-XP as a contender in the discussion. I plan to explore in future work the possibility that we are facing a case of untypical syntax.

Hale and Keyser (2002:Ch.3) discuss similar constructions in English, shown in (45) on the left. They are interested in the verb formation process shown on the right.

- (45) a. John put the wine in (a) bottle(s) John bottled the wine.
 b. John put the apples in (a) bag(s) John bagged the apples.
 c. Leecil put the calves in the corral John corralled the calves.

These verbs can include the concepts of the directional PP as shown. Hale and Keyser argue that more is involved than syntactic head movement (incorporation). First, they argue that head movement can proceed from the specifier of a complement to a higher head. Conflation does not allow this. In the cases in (45), this would result in inclusion of the theme in the verb: A construction like 'John put the apples in bags' would result in verb formation like *'John appled in bags'. This does not occur. Second, this word formation process will sometimes allow the kind of complement originally incorporated into the verb:

- (46) John shelved the books on the windowsill.
 John bagged the potatoes in a gunnysack.

Hale and Keyser define a novel process of conflation with these properties. For them, the input to conflation is the structure $[_{VP} V [_{PP} [the\ apples] (in)\ bag]]$, with conflation of '(in) bag' with the higher verb.

For the sake of exploration, let us tentatively redefine conflation in terms of the VP-shells employed in this paper. In these terms, conflation may be thought of along the lines of V' reanalysis in Larson (1988), namely as a process in which a V' is turned into a verbal head. (47) shows the derivation of 'bag the apples'. In step b. the original V' is turned into V by conflation. In step c., this newly formed head undergoes head movement in the shell.

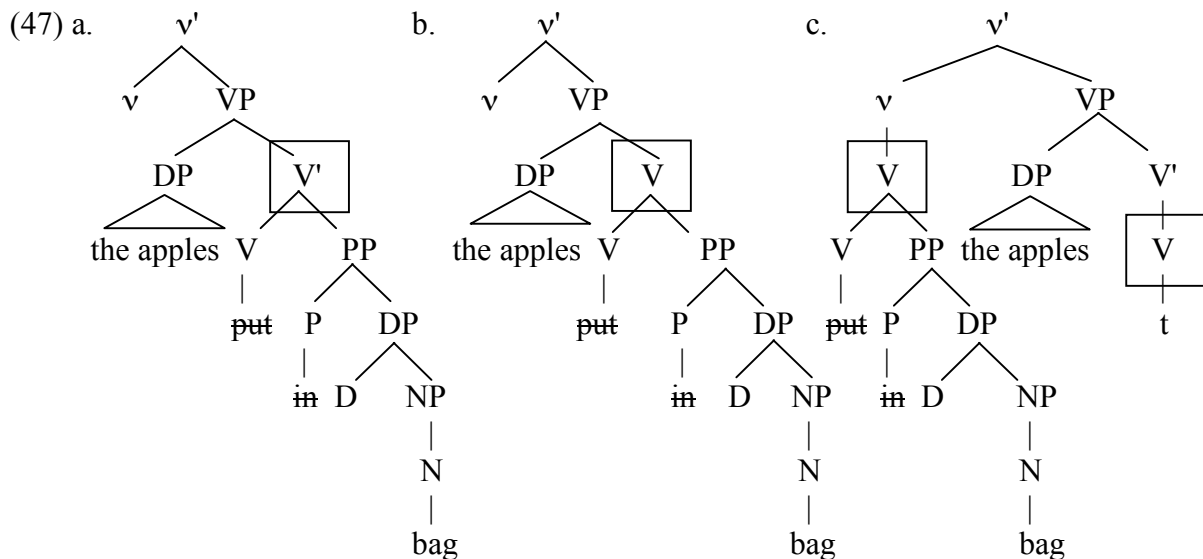

The understanding of conflation as V' reanalysis would have the desired properties. First, the theme ('the apples' in (45)) does not participate in this word formation process, since it is in a specifier position outside of V'. Second, the observation in (46) finds a place. Assume that after the joining of V and PP to $[_{v'} V PP]$ conflation applies to give $[_{v'} V PP]$. This newly formed head can now take a directional PP complement into its (to-be-created) V' projection. To be sure, conflation violates traditional assumptions about structure preservations: Phrases do not normally become parts of heads.

The parallel of interest for the German stress-facts is that in those cases in which English allows verb formation, i.e. somehow joining what is otherwise a phrase into a verbal head, German allows absence of stress. Assume that conflation applied to the relevant structure (48a) in German, deriving (48b).

(48) a.

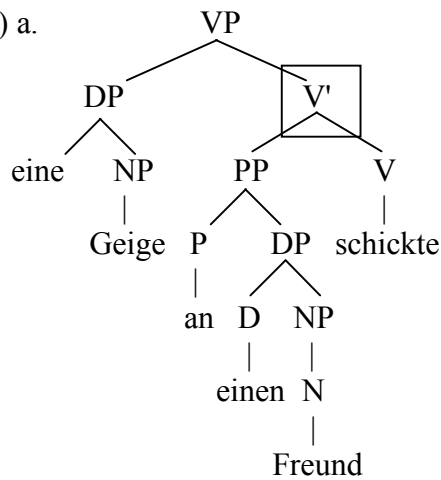

a violin to a friend sent

b.

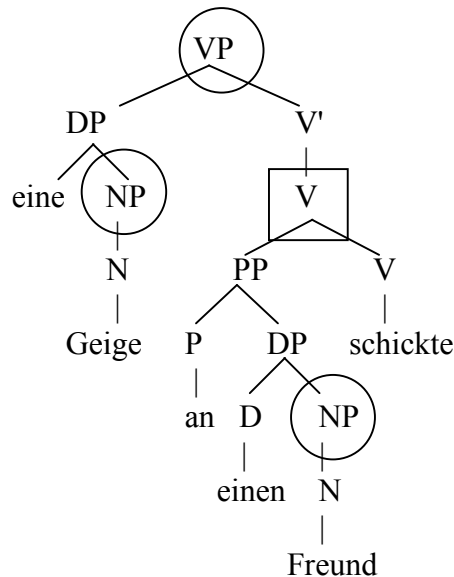

In (48b), there would be a plausible reason for not stressing the PP. The demands of Stress-XP in the PP may be in conflict with demands on the boxed constituent V to be mapped to, or wrapped in, a prosodic word. Where this latter requirement would win out, the PP would end up stressless.

Some syntactic arguments for a particular closeness of this class of PPs to the verb in German can be found in Steinitz (1989) and Frey (1993). For the syntax of Persian, Kahnemuyipour (2004:95f) cites references for the syntactic analysis he adopts, and cites Karimi (2003), who presents arguments that point in the direction outlined here.

I leave all this to future work, merely noting here that a defense of Stress-XP may not be entirely hopeless in the face of the German stressless PPs and related facts in Persian.

4. Phases vs. phrases: concluding remarks on the relation of the two accounts

Here I wish to highlight some elements in which the two accounts discussed differ, and some elements that they share.

Let us take a generalization from the SAAR of Gussenhoven (1992) as a starting point: Inside of a focus, non-given arguments and adjuncts receive accent (here: phrasal stress; Gussenhoven 1992:98ff treats stressless locative PPs as predicates).

Stress-XP takes this surface-generalization at face value, and maintains that it is the lexical XPs inside of the arguments and adjuncts that require this stress. Exceptions are the German stressless PPs and similar stress-patterns in Persian VPs described by Kahnemuyipour (2004), assuming standard syntactic analyses of these. Stress-XP extends to VPs without further ado: The verb is stressed if it constitutes a VP on its own (or together with a pronoun). It is not stressed if another lexical XP inside of the VP requires phrasal stress independently.

The account of Kratzer and Selkirk (2007) in terms of phases takes the observations of Kahnemuyipour (2004) and the German stressless PPs as one of their starting points. In some sense, matters are here shifted up in the tree, relative to earlier accounts including the Stress-XP account. For the typical argument and adjunct, stress-assignment is triggered with the constituent dominating them, a spellout domain of a phase, of which the argument or adjunct is the highest XP. This requires, in the end, a phase for each beat of phrasal stress in the sentence. This was shown for DP arguments in the text above. Adjuncts will similarly require additional phases. A plausible conception for additional phases of this kind lies with the suggestion of Kratzer and Selkirk (2007) that topic phrases introduce additional phases, where these topic phrases are identified with landing sites of scrambling.

The 'shift up in the tree' leads to the need for a separate statement concerning stress on the verbs, the Elsewhere Condition, which mirrors the effect of Stress-XP: The VP spellout domain requires phrasal stress. Seen from the point of view of Stress-XP, the resulting dichotomy in principles of stress-assignment may be seen as a price to pay for 'shifting up in the tree' of the stress-trigger of constituents other than the verb. However, if the phrasal account is on the right track, the Elsewhere Condition seems to be natural.

I have mainly explored how the effects of indefinite pronouns and traces of the direct object generalize from transitive sentences to ditransitive sentences. Kratzer and Selkirk (2007) suggested that the option of raising of the verb or verbs in the VP-shell correlates with the absence of an overt direct object pronoun. This proves to be fruitful in the extension of their account to ditransitive sentences. It also proves to be fruitful in an account of these patterns in terms of Stress-XP. I pointed out that a weakened version of Kayne's LCA may also be at play in restricting possible verb positions.

Lisa, I hope that there is something in this discussion that you enjoy thinking about. Much pleasure in the years ahead, with time for research!

References

- Baker, M. C. (1988) *Incorporation: a Theory of Grammatical Function Changing*. Chicago: University of Chicago Press.
- Bayer, J. and Kornfilt, J. (1994) Against scrambling as an instance of Move-alpha. In H. v. Riemsdijk and N. Corver (eds.) *Studies on Scrambling: Movement and Non-movement Approaches to Free Word-order Phenomena* 17--60. Berlin: Mouton de Gruyter.
- Chomsky, N. (2008) On Phases. In R. Freidin, C. P. Otero, and M. L. Zubizarreta (eds.) *Foundational Issues in Linguistic Theory. Essays in Honor of Jean-Roger Vergnaud* 133--166. Cambridge, Mass.: MIT Press.
- Diesing, M. (1992) *Indefinites*. Cambridge, Mass.: MIT Press.
- Fanselow, G. (2001) Features, theta-roles, and free constituent order. *Linguistic Inquiry* 32: 405--437.
- Fanselow, G. (2003) Free constituent order: a minimalist interface account. *Folia Linguistica* 37: 191--231.
- Féry, C. and Samek-Lodovici, V. (2006) Focus projection and prosodic prominence in nested foci. *Language* 82: 131--150.
- Frey, W. (1993) *Syntaktische Bedingungen für die semantische Interpretation. Über Bindung, implizite Argumente und Skopus*. Berlin: Akademie Verlag.
- Gussenhoven, C. (1983) Focus, mode and the nucleus. *Journal of Linguistics* 19: 377--417.
- Gussenhoven, C. (1992) Sentence accents and argument structure. In I. Roca (ed.) *Thematic Structure, its Role in Grammar* 79--106. Berlin, New York: Foris.
- Haider, H. and Rosengren, I. (2003) Scrambling: nontriggered chain formation in OV languages. *Journal of Germanic Linguistics* 15: 203--267.
- Hale, K. and Keyser, S. J. (2002) *Prolegomenon to a Theory of Argument Structure*. Cambridge, Mass.: MIT Press.
- Jackendoff, R. S. (1972) *Semantic interpretation in generative grammar*. Cambridge, Mass.: MIT Press.
- Jäger, G. (2001) Topic-comment structure and the contrast between stage level and individual level predicates. *Journal of Semantics* 18: 83--126.
- Kahnemuyipour, A. (2004) *The Syntax of Sentential Stress*. Doctoral thesis, University of Toronto.
- Karimi, S. (2003) On object positions, specificity and scrambling in Persian. In S. Karimi (ed.) *Word Order and Scrambling* 91--125. London: Blackwell.
- Kayne, R. (1994) *The Antisymmetry of Syntax*. Cambridge, Mass.: MIT Press.

- Kratzer, A. (1995) Stage-level and individual-level predicates. In G. N. Carlson and J. F. Pelletier (eds.) *The Generic Book* 125--175. Chicago: Chicago University Press.
- Kratzer, A. and Selkirk, E. (2007) Phase theory and prosodic spellout: the case of verbs. *The Linguistic Review* 24: 93--135.
- Krifka, M. (1984) Focus, Topic, syntaktische Struktur und semantische Interpretation. Ms. Universität München.
- Ladd, D. R. (1983) Even, focus, and normal stress. *Journal of Semantics* 2: 257--270.
- Larson, R. (1988) On the double object construction. *Linguistic Inquiry* 19: 335--391.
- Müller, G. (1999) Optimality, markedness and word order in German. *Linguistics* 37: 777--818.
- Ramchand, G. (2008) *Verb Meaning and the Lexicon. A First-phase Syntax*. Cambridge: Cambridge University Press.
- Rooth, M. (1996) Focus. In S. Lappin (ed.) *The Handbook of Contemporary Semantic Theory* 271--297. Oxford and Cambridge, Mass.: Blackwell.
- Samek-Lodovici, V. (2005) Prosody-syntax interaction in the expression of focus. *Natural Language and Linguistic Theory* 23: 687--755.
- Selkirk, E. and Shen, T. (1990) Prosodic domains in Shanghai Chinese. In S. Inkelas and D. Zec (eds.) *The Phonology-Syntax Connection* 313--337. Chicago: The University of Chicago Press.
- Selkirk, E. and Tateishi, K. (1991) Syntax and Downstep in Japanese. In C. Georgopolous and R. Ishihara (eds.) *Interdisciplinary Approaches to Language: Essays in Honor of S.-Y. Kuroda* 519--543. Dordrecht: Kluwer.
- Selkirk, E. 2006. Contrastive focus, givenness and phrase stress. Ms., University of Massachusetts, Amherst.
- Selkirk, E. O. (1984) *Phonology and Syntax: the Relationship between Sound and Structure*. Cambridge, Mass; London, England: MIT Press.
- Selkirk, E. O. (1986) On derived domains in sentence phonology. *Phonology Yearbook* 3: 371--405.
- Selkirk, E. O. (1995) The prosodic structure of function words. In J. Beckman, L. W. Dickey, and S. Urbanczyk (eds.) *Papers in Optimality Theory. University of Massachusetts Occasional Papers* 18 439--469. GLSA, Amherst, Mass.
- Steinitz, R. (1989) V^u, I^y und I^z: Überlegungen zum Prädikativ. In W. Motsch (ed.) *Wortstruktur und Satzstruktur* 210--234: Akademie der Wissenschaften der DDR, Zentralinstitut für Sprachwissenschaft.
- Truckenbrodt, H. (1995) *Phonological Phrases: their Relation to Syntax, Focus, and Prominence*. Doctoral thesis, MIT.
- Truckenbrodt, H. (1999) On the relation between syntactic phrases and phonological phrases. *Linguistic Inquiry* 30: 219--255.
- Truckenbrodt, H. (2006) Phrasal Stress. In K. Brown (ed.) *The Encyclopedia of Languages and Linguistics, 2nd Edition, Vol. 9* 572--579. Oxford: Elsevier.
- Truckenbrodt, H. (2007) The syntax-phonology interface. In P. de Lacy (ed.) *The Cambridge Handbook of Phonology* 435--456. Cambridge: Cambridge University Press.
- Truckenbrodt, H. and Darcy, I. (2010) Object clauses, movement, and phrasal stress. In N. Shir and L. Rochman (eds.) *The Sound Patterns of Syntax* 189--216. Oxford: Oxford University Press.
- Uhmann, S. (1991) *Fokusphonologie. Eine Analyse deutscher Intonationskonturen im Rahmen der nicht-linearen Phonologie*. Tübingen: Niemeyer.